

ROTODOSER

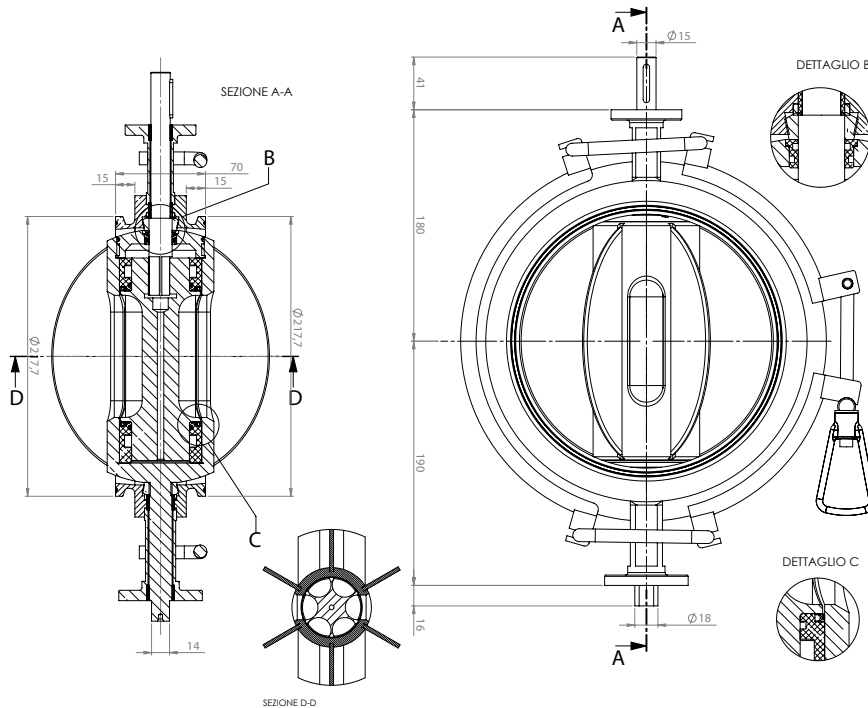

Rotodoser is a solution designed for accurate dosing and consists of two concentric rotors of different volume individually operated, which determine product flow and dosing. The main rotor ensures continuous product flow while the secondary rotor ensures accurate dosing. (Rotors can be customized)



TYPICAL APPLICATIONS:

Feeding of packaging machines, drum and bag filling systems, dispensing

MAIN FEATURES:

- Manufactured according to cGMP and EHEDG guidelines
- Suitable for CIP and SIP

MATERIALS:

- Body: Stainless steel EN 1.4404 (AISI 316L)
- Main rotor: Stainless steel EN 1.4404 (AISI 316L)
- Secondary rotor: Stainless steel EN 1.4404 (AISI 316L)
- Seals: Translucent Silicone, EPDM, FKM (Viton®)

MOTION DRIVE:

- Pneumatic actuator (main rotor)
- Pneumatic or electric motor (secondary rotor)
- Pneumatic actuator (secondary rotor)

DECLARATIONS AND CERTIFICATIONS:

- FDA Certification (CFR § 177.2600)
- Material Certificate 3.1 as per EN10204
- ATEX

SIZES:

100	150	200	250	300
-----	-----	-----	-----	-----

FINISH:

Ra 0.5 µm internal, 1.2 µm external